

PDUVCC

UV-C control system

Control solution for UV-C surface disinfection systems

The Philips Dynalite PDUVCC control solution is a vital part of a properly designed and installed UV-C lighting system, that allows the system to be used and operated with greater safety than a system without an equivalent control solution in place.

This preconfigured solution incorporates switched outputs for driving Philips UV-C lamps and third-party audio alarms and warning lights. It also features an onboard settings interface, authorized key switch activation, lamp maintenance reporting, integrated Dynalite motion sensors, checkpoint buttons, and inputs for third-party emergency shutoff buttons and area safeguard door switches.

PDUVCC

Control solution for UV-C surface disinfection systems

- **Single-box solution** – Assembled, programmed, and tested in the factory to provide complete out-of-the-box functionality.
- **Integrated AntumbraDisplay** – Allows authorized users to adjust UV-C disinfecting dosage and monitor lamp life management. Includes multi-language support.
- **Physical key switch protection** – Helps to ensure that only authorized users can modify settings or activate the system.
- **External control inputs** – Robust, reliable connection to door switches, emergency shutoff buttons, and vacancy confirmation checkpoints.
- **Motion sensor integration*** – Designed to work with Dynalite's best-in-class network sensors to automatically shut down the UV lamps if motion is detected in the disinfection area.
- **System status indicators** – Eight clearly labelled LEDs on the front of the enclosure show the device's status at a glance.
- **Onboard event logging** – All system events are logged and timestamped for reporting.
- **Ethernet connectivity** – Enables secure network access to configuration and event logs via System Manager head-end software.

Dimensions

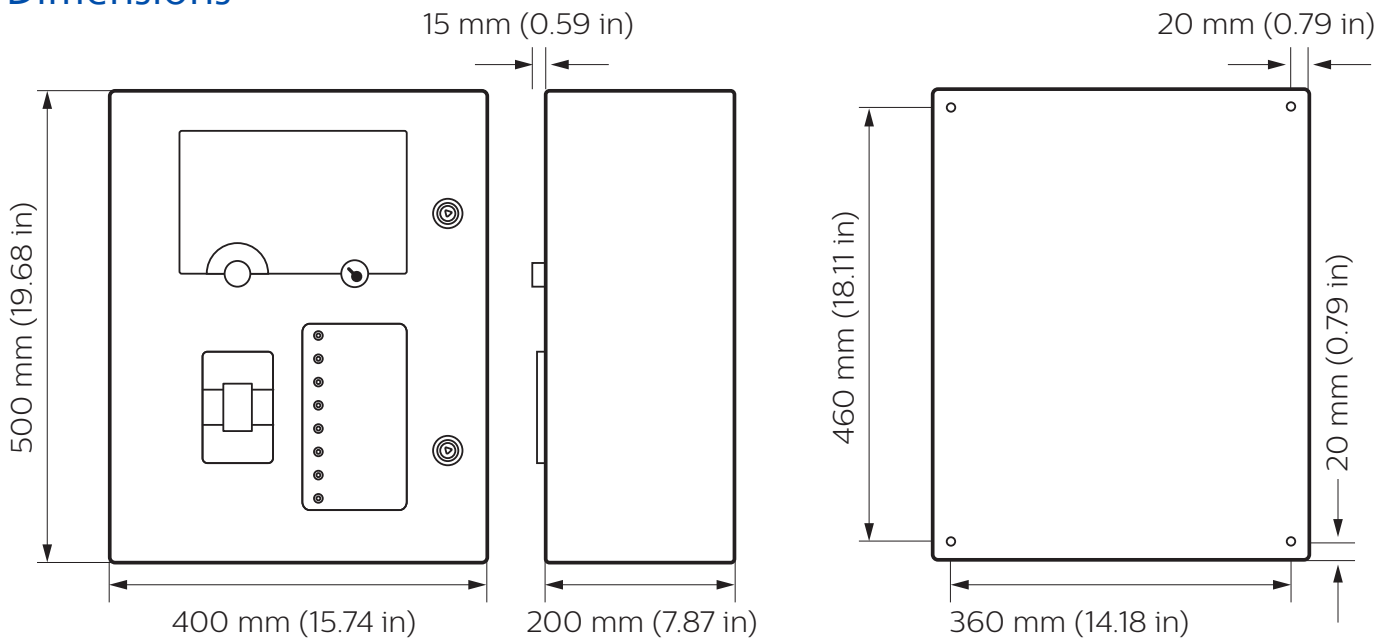

Third-Party Devices

The PDUVCC is designed to integrate with third-party safety and warning devices conforming to the recommendations below.

Device	Function	Action	Electrical Requirements
Occupant warning alarm	Warns occupants that the UV-C lamp cycle is about to begin	Flashing lights, audio alarm, or any other warning devices as per local regulations	max 16 A, 100-230 VAC (AC-1)
Emergency stop button (red)	Immediately stops the UV-C lamp cycle	Normally closed momentary push-button switch	
Door switch	Ensures that all doors to the UV-C area are closed before UV-C cycle can begin	Closed contact when door is closed.	Rated switching voltage: ≥ 24 VAC/DC Rated switching current: ≥ 0.5 A Minimum switching capacity: ≤ 10 mA @ ≤ 5 VAC/DC
Checkpoint button (yellow)	Confirms that the authorised user has physically inspected the area for occupants before UV-C cycle can begin	Normally open momentary push-button switch	

* Sensors must not be relied on as a safety measure. The authorized user should always perform a visual check of the area before starting the disinfection cycle.

Specifications

Due to continuous improvements and innovations, specifications may change without notice.



PDUVCC
UV-C Control System

Electrical

Supply	100-230 VAC @ 20 A
Switched UV-C Lamp Outputs	See Output Ratings table below
Switched Alarm Output	See Output Ratings table below
External Control Inputs	12 VDC @ 0.5 A (max)
DyNet Output	12 VDC @ 0.5 A (SELV)
Electrical Protection	20 A (max) per input
IEC Overvoltage Category	III

Control

Serial Ports	1 x RS-485 1 x Ethernet (10/100 baseT, future provision)
Supported Protocols	DyNet TCP/IP (IPv4/IPv6, future provision)
External Control Inputs	4 x area checkpoint 1 x door switch channel 1 x emergency stop channel
Diagnostic Functions	Device online/offline status 28-day rolling event log
User Controls	3-position key switch (Off, Armed, Start) Emergency Stop button 6-button AntumbraDisplay
Indicators	8 x status LED AntumbraDisplay LCD screen

Output Ratings

Load Type	UV-C Lamps	Alarms
Electronic Driver	3 x 16 A, 100-230 VAC (single or three-phase) (500 A inrush)	
AC-1		16 A, 100-230 VAC (single-phase only)

Refer to Installation Instructions for more information.

Physical

Dimensions (H x W x D)	500 x 400 x 200 mm (19.69 x 15.75 x 7.87 in)
Packed Weight	PDUVCC-10: 17.5 kg (38.6 lb) PDUVCC-20: 19.1 kg (42.1 lb) PDUVCC-30: 20.8 kg (45.9 lb)
Construction	Steel wall mount enclosure Powder coat finish
Color	RAL7035 (Grey)
Serial Ports	1 x 5-way pluggable screw terminal 1 x RJ45 (future provision)
Serial Port Conductor Size	0.1-2.5 mm ² (28-12 AWG)
Supply Terminals	5 x screw terminal
Supply Terminal Conductor Size	1.5-16 mm ² (16-6 AWG)
Output Terminals	5 x screw terminal
Output Terminal Conductor Size	1.5-16 mm ² (16-6 AWG)
External Control Input Terminals	1 x 9-way pluggable screw terminal 1 x 6-way pluggable screw terminal
External Control Input Terminal Conductor Size	0.1-2.5 mm ² (28-12 AWG)
External Control Max Wiring Distance	75 m (82 yd) @ 0.75 mm ² (18 AWG)
Earth Bar Terminals	14 x screw terminal
Earth Bar Terminal Conductor Size	1.5-21 mm ² (16-4 AWG)
Neutral Bar Terminals	7 x screw terminal
Neutral Bar Terminal Conductor Size	1.5-16 mm ² (16-6 AWG)

Environment*

Operating Temperature	0° to 40°C ambient (32° to 104°F)
Storage/Transport Temperature	-25° to 60°C ambient (-13° to 140°F)
Relative Humidity	0 to 90% non-condensing
IP Rating	IP30 (indoor use only, see PDUVCC Installation Instructions)
IEC Pollution Degree	II

Compliance

Certification	CE, RCM, UKCA, RoHS
---------------	---------------------

* For indoor installation only



System Overview

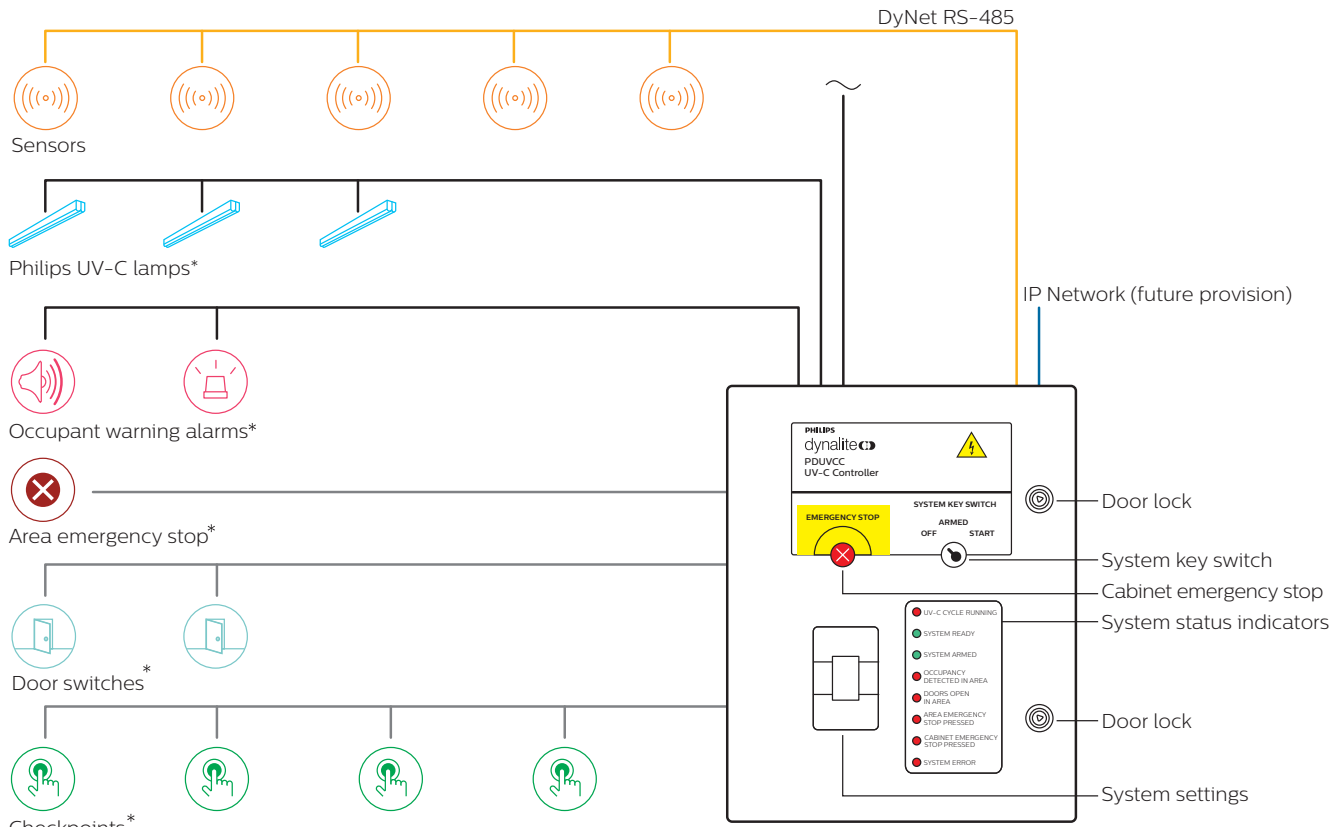

* UV-C lamps and third-party devices not supplied by Dynalite

Ordering Code

Product

Product	12NC
PDUVCC-10* (UV-C Controller + 10 Sensors)	913703073709
PDUVCC-20* (UV-C Controller + 20 Sensors)	913703073809
PDUVCC-30* (UV-C Controller + 30 Sensors)	913703074309

* Ensure that only the required number of sensors are installed for your space. Remaining sensors can be kept as spares. Only install sensors supplied with the system.

DACM Language and Label Kits

DACM Language and Label Kits	12NC
German (label kit)	913703248209
Chinese (label kit)	913703248309
Italian (label kit + DACM)	913703248409
French (label kit + DACM)	913703248509
Spanish (label kit + DACM)	913703248609
Polish (label kit + DACM)	913703248709
Dutch (label kit + DACM)	913703248809
Japanese (label kit + DACM)	913703248909

© 2024 Signify Holding.

All rights reserved. Specifications are subject to change without notice. No representation or warranty as to the accuracy or completeness of the information included herein is given and any liability for any action in reliance thereon is disclaimed. Philips and the Philips Shield Emblem are registered trademarks of Koninklijke Philips N.V. All other trademarks are owned by Signify Holding or their respective owners.



www.dynalite.com

Revision 11 – 2024-01-18